



FORMATURA
INIEZIONE
POLIMERI

SV



FIP



SV

FIP

SV

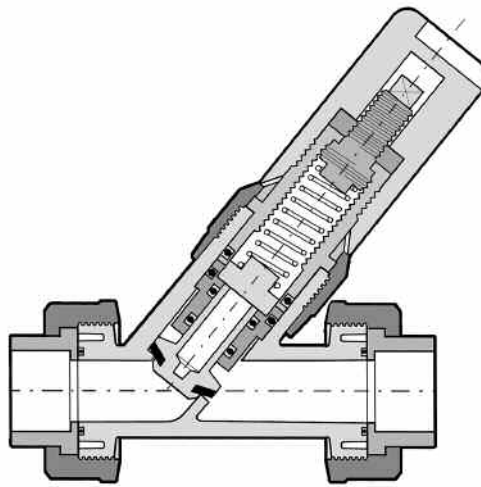

d
DN
R
PN

() ()
() ()

g
PVC
EPDM
NBR

() 20°

FIP

FIP



16 bar

0.3 ÷ 4 bar

EPDM - FPM

PVC

1

(PN) (25)

FIP

ISO727, UNI 7442/75, DIN 8063, NF T54-028, BS 4346/1, ASTM 2467/76
 ISO161/1, UNI 7442/75, DIN 8062, NF T54-016, BS3506,
 BS3505, ASTM D 1785/76.

SVDV

U-PVC

ISO

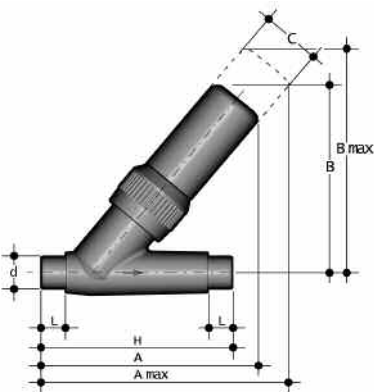

d	DN	A	A max	B	B max	C	H	L	g
20	15	158,5	198,5	118	170	34	124	16	300
25	20	198	278	150	220	40	144	19	470
32	25	237	307	175	230	48	154	22	860

SVUIV

U-PVC

ISO

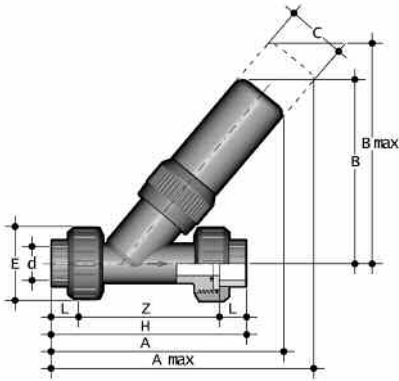

d	DN	A	A max	B	B max	C	H	L	E	Z	g
20	15	153	193	118	170	34	135	16	55	103	391
25	20	191	271	150	220	40	158	19	66	120	633
32	25	226	296	175	230	48	176	22	75	132	1106

SVUFV

U-PVC

BSP

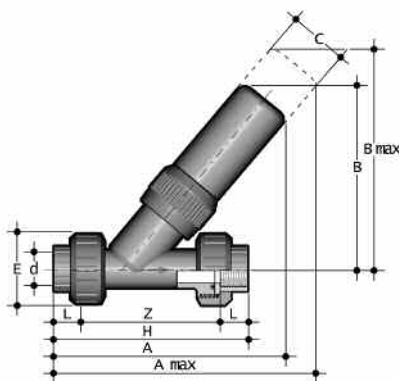

R	DN	A	A max	B	B max	C	H	L	E	Z	g
1/2"	15	153	193	118	170	34	135	15,0	55	112,0	391
3/4"	20	191	271	150	220	40	158	16,3	66	126,4	633
1"	25	226	296	175	230	48	176	19,1	75	144,8	1106

1)

2)

3)

4)

5)

6)

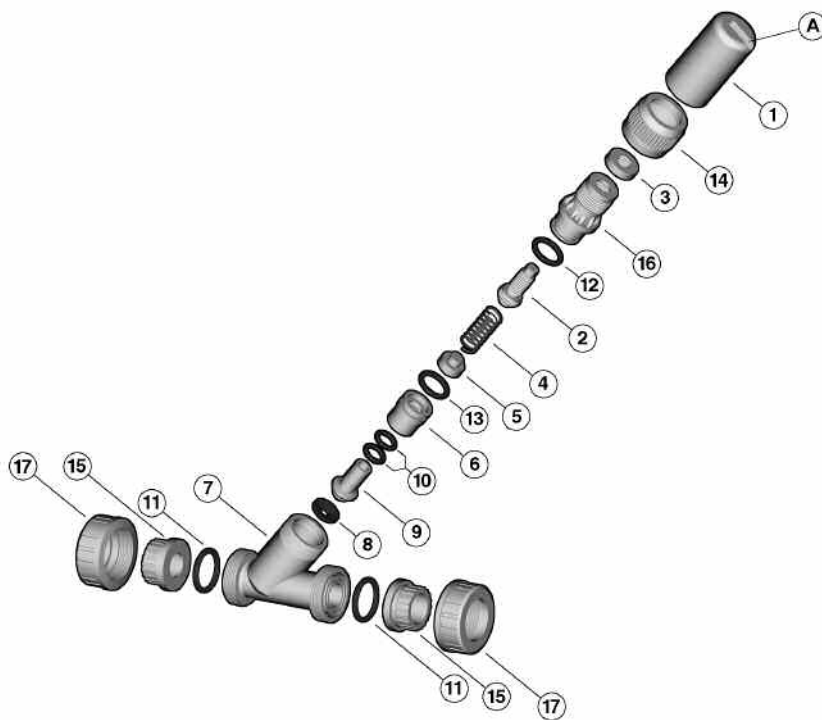
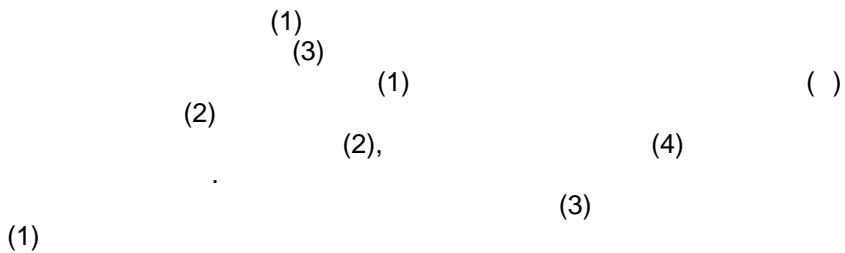

.			
1		PVC	1
2		PVC	1
3		PVC	1
4			1
5		PVC	1
6		PVC	1
7		PVC	1
8		EPDM FPM	1
9		PVC	1
10		EPDM FPM	2
11		EPDM FPM	2
12		EPDM FPM	1
13		EPDM FPM	1
14		PVC	1
15		PVC	2
16		PVC	1
17		PVC	2